

“Bokumatic” Automatic Recess Tool Holders

Designed for Multiple Spindle Screw Machines



Model U-DB

Model A-DB

Model C-DB

For Machines
7/16" - 5 1/2"
Capacity



TRADE MARK REG. U.S. PAT. OFF.

BOKUM TOOL COMPANY inc.

75 Years of Precision Manufacturing

BOKUM TOOL COMPANY

Models A-DB, C-DB and U-DB Recess Tool Holders DESIGNED FOR MULTIPLE SPINDLE SCREW MACHINES

- The Bokumatic Draw Bar Attachment was introduced in 1970.
- Our Spiral Cam Design provides exceptional accuracy for holding closer tolerances.
- Simple mechanism consists of (3) primary components.
 - Repair parts are inexpensive and easily installed.
- Tool change time is minimized with our optional "Pre-set Feature".
 - Our Circular form tools engage a positive locator, eliminating the need to adjust for diameter after resharpening.
- Common applications are back chamfering before cut-off and thread recessing before tapping
 - Bokum stocks a full line of standard recess tools
 - Complex special cutting tools available as well (Please consult our engineering department for a quote on your job).

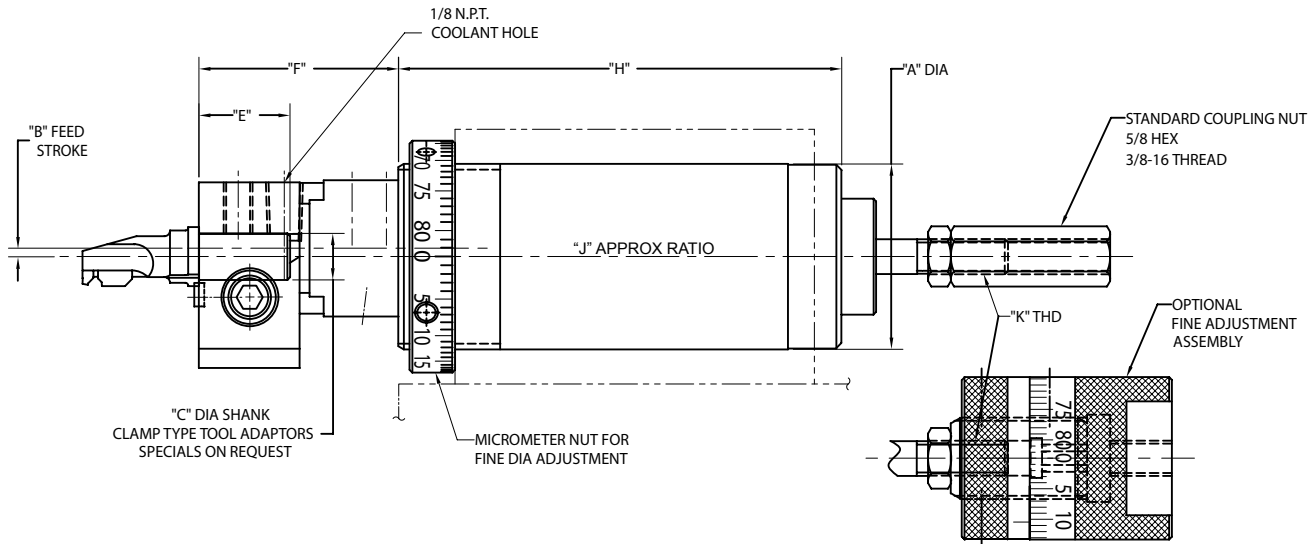

MODEL	A	B	C	E	F	H	J	K
A-DB	<u>1.4995</u> 1.4990	.100	3/8, 1/2, 5/8	1.25	1.38	4.68	6:1	3/8-16
C-DB	<u>1.9995</u> 1.9990	.125	1/2, 5/8, 3/4, 1	1.00	2.19	4.88	7:1	3/8-16
U-DB	<u>2.9995</u> 2.9990	.250	1/2, 5/8, 3/4, 1 1 1/4, 1 3/8, 1 1/2	1.50	2.90	5.25	4.5:1	7/16-20

Tool Adaptors with RR designation are for Radial Relief type tools. Adaptors with CF designation are for Circular Form type tools

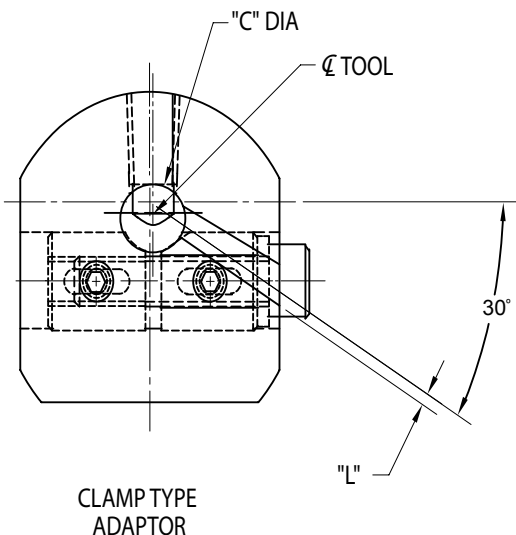

ADAPTOR NO. FOR A-DB	C Shank Dia	L Tool Offset	Normal Dia. of Hole To Be Recessed
A(shank dia.) RR	3/8, 1/2, 5/8"	.000	1/8" - 1 3/4"
A(shank dia.) CF-1		.026	1/4" - 1"
ADAPTOR NO. FOR C-DB			
CC(shank dia.) RR	1/2, 5/8, 3/4, 1"	.000	1/8" - 1 3/4"
CC(shank dia.) CF-1		.026	1/4" - 1"
CC(shank dia.) CF-2		.062	3/4" - 1 3/4"
ADAPTOR NO. FOR U-DB			
UC(shank dia.) RR	1/2, 5/8, 3/4, 1" 1 1/4, 1 3/8, 1 1/2"	.000	1/8" - 3"
UC(shank dia.) CF-1		.026	1/4" - 1"
UC(shank dia.) CF-2		.062	3/4" - 1 3/4"
UC(shank dia.) CF-3		.108	1 1/4" - 3"



BOKUM TOOL COMPANY inc